

Series “A” Flow Control Valves

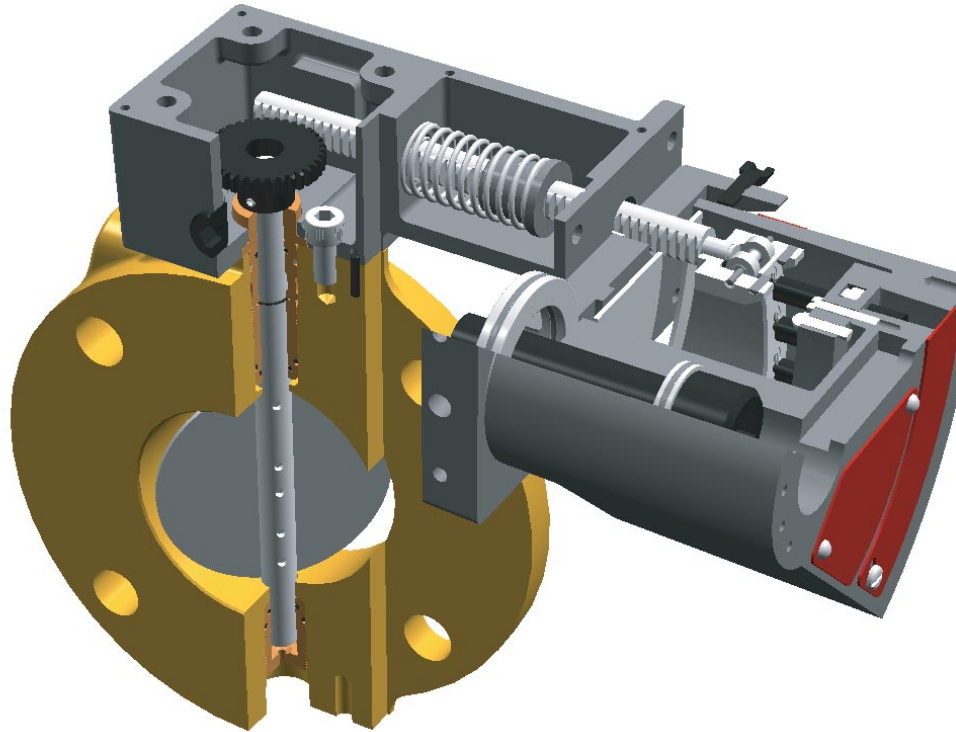

Cut-away of 3" positive push/pull SYNCHRO Valve

- **Valve bodies are designed to meet ANSI specifications** (DIN flange option for future availability)
- **High pressure rating**
- **Cast iron, carbon steel and brass bodies**
- **Positive push/pull actuator**
- **SYNCHRO Valves** may be used independently for individual adjustable gradient fuel flow control, or in tandem with other fuel control valves for more sophisticated multi-zone control or multi-fuel applications.
- **Low torque**



Series "A" Flow Control Valves

Design and Application Details

Principle of Operation

MICRO-RATIO® Valve assemblies typically consist of an air butterfly valve mechanically linked to one or more adjustable gradient SYNCHRO Fuel Control Valves(s).

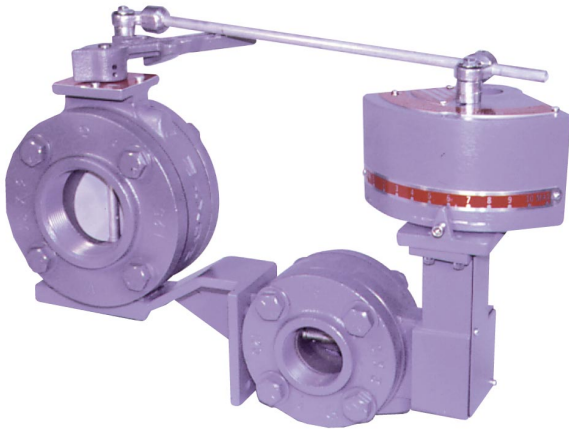

View of a A-3" x 1-1/2" -A MICRO-RATIO® Valve

The tandem linkage gives accurate proportioning of air/fuel(s) ratios required for your specific burner system/application.

The multiple screw adjustment feature of the SYNCHRO Valve provides a mechanical means of adjusting the air/fuel(s) ratios at each of twelve valve positions throughout the capacity range of each valve. This provides accurate fuel/air control.

Air-gas-oil valves in tandem-linked combination are ideal for multi-zone or stand-by fuel system control.

Air-gas-oil SYNCHRO Valves may be used independently for single control or throttling of multiple burners.

Nomenclature

MICRO-RATIO® Valve assemblies are designated by listing the individual valves, starting with the air valve, then each of the fuel valves to be included, as well as their relative position in the assembly (bottom to top).

Examples:

"Duplex" MICRO-RATIO® Valve assembly

A-4" X 1-1/2" -A
(air) X (gas)

"Quadriplex" MICRO-RATIO® Valve assembly

M- 10" X 4" -A X 1/2" -O -200 X 2" -A
(air) X (gas) X (oil) X (gas)

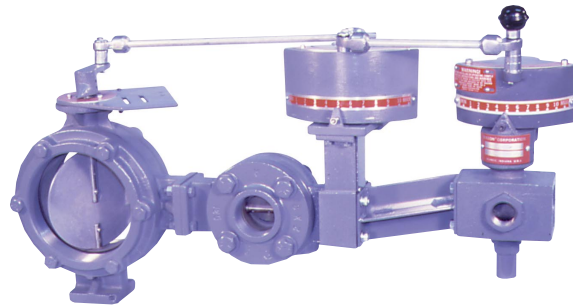

View of Triplex M-6" x 1-1/2" -A x 1/2" -P

Design Features

Series "A" Flow Control Valves are available in manual handle and positive push/pull SYNCHRO versions.

Valve bodies are available in cast iron, steel and brass versions. All versions have a stainless steel shaft and disc. Brass versions are compatible for oxygen service.

The positive push/pull actuator is tested to over 250,000 cycles.



CORPORATION

201 East 18th Street, P.O. Box 2068, Muncie, Indiana, 47307-0068. Phone: (765) 284-3304. FAX: (765) 286-8394

Capacities and Specifications

General

All Maxon Flow Control Valves are designed for throttling service only and are not intended for tight shut-off.

Flow direction is not a factor with butterfly-type valve bodies. However, with poppet-type SYNCHRO Valves, fluid flow through the valve must only be in the direction indicated by the arrowhead cast into each valve body.

Series "A" Manual Control Valves

Size	Maximum Cv Rating	Minimum Controllable Cv Rating	Maximum Inlet Pressure (psig)	Maximum Body Pressure (psig)	Torque Required (in-lbs)	Maximum Fluid Temperature (°F)	
						Iron & Steel	Brass
1"	27	.50	100	100	10	250	400
1.25"	70	.60	100	100	20	250	400
1.5"	105	.70	100	100	30	250	400
2"	190	1.30	100	100	65	250	400
2.5"	260	2.40	90	100	100	250	400
3"	360	3.00	60	100	125	250	400
4"	750	5.00	30	100	140	250	N/A

C_v factors based on flow through a wide-open valve.

Torque required is shown for maximum rated pressure. At lower pressures, less torque may be required.

Series "A" SYNCHRO Control Valves

Size	Maximum Cv Rating	Minimum Controllable Cv Rating	Maximum Inlet Pressure (psig)	Maximum Body Pressure (psig)	Torque Required (in-lbs)	Maximum Fluid Temperature (°F)	
						Iron & Steel	Brass
1"	27	.50	100	100	55	250	400
1.25"	70	.60	100	100	60	250	400
1.5"	105	.70	100	100	70	250	400
2"	190	1.30	55	100	75	250	400
2.5"	260	2.40	30	100	75	250	400
3"	360	3.00	16	100	75	250	400
4"	750	5.00	8	100	75	250	N/A

C_v factors based on flow through a wide-open valve.

Torque required is shown for maximum rated pressure. At lower pressures, less torque may be required.

Torque Requirements listed in tables above are important and are to be used in selecting your automatic control operators. Torque figures (inch-pounds) are additive for your complete MICRO-RATIO® Valve assembly.

Example: For A-4" x 1-1/2" -A MICRO-RATIO® Valve:
 A-4" requires 140 in-lbs
 1-1/2"-A requires 70 in-lbs
 4"-A x 1-1/2" A assembly requires 210 in-lbs

The automatic control motor must be capable of developing at least 210 in-lbs of torque in order to throttle this particular MICRO-RATIO® Valve combination.

Dimensions *(in inches)* Valve Body

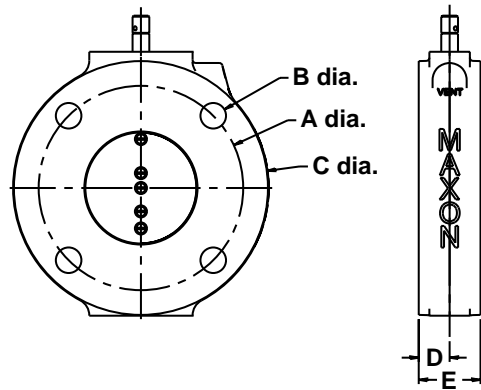

Cast Iron Bodies

Size	A	B	C	D	E
1"	3.12	0.63	4.25	0.66	1.31
1.25"	3.50	0.63	5.00	0.66	1.31
1.5"	3.88	0.63	5.00	0.66	1.31
2"	4.75	0.75	6.00	0.84	1.69
2.5"	5.50	0.75	7.50	0.91	1.81
3"	6.00	0.75	7.50	0.91	1.81
4"	7.50	0.75	9.00	1.03	2.06

Carbon Steel Bodies

Size	A	B	C	D	E
1"	3.12	0.63	4.25	0.66	1.31
1.25"	3.50	0.63	5.00	0.66	1.31
1.5"	3.88	0.63	5.00	0.66	1.31
2"	4.75	0.75	6.00	0.84	1.69
2.5"	5.50	0.75	7.50	0.91	1.81
3"	6.00	0.75	7.50	0.91	1.81
4"	7.50	0.75	9.00	1.03	2.06

Brass Bodies

Size	A	B	C	D	E
1"	3.12	0.63	4.25	0.66	1.31
1.25"	3.50	0.63	5.00	0.66	1.31
1.5"	3.88	0.63	5.00	0.66	1.31
2"	4.75	0.75	6.00	0.84	1.69
2.5"	5.50	0.75	7.50	0.91	1.81
3"	6.00	0.75	7.50	0.91	1.81

Dimensions *(in inches)*

Series "A" Manual Control Valves

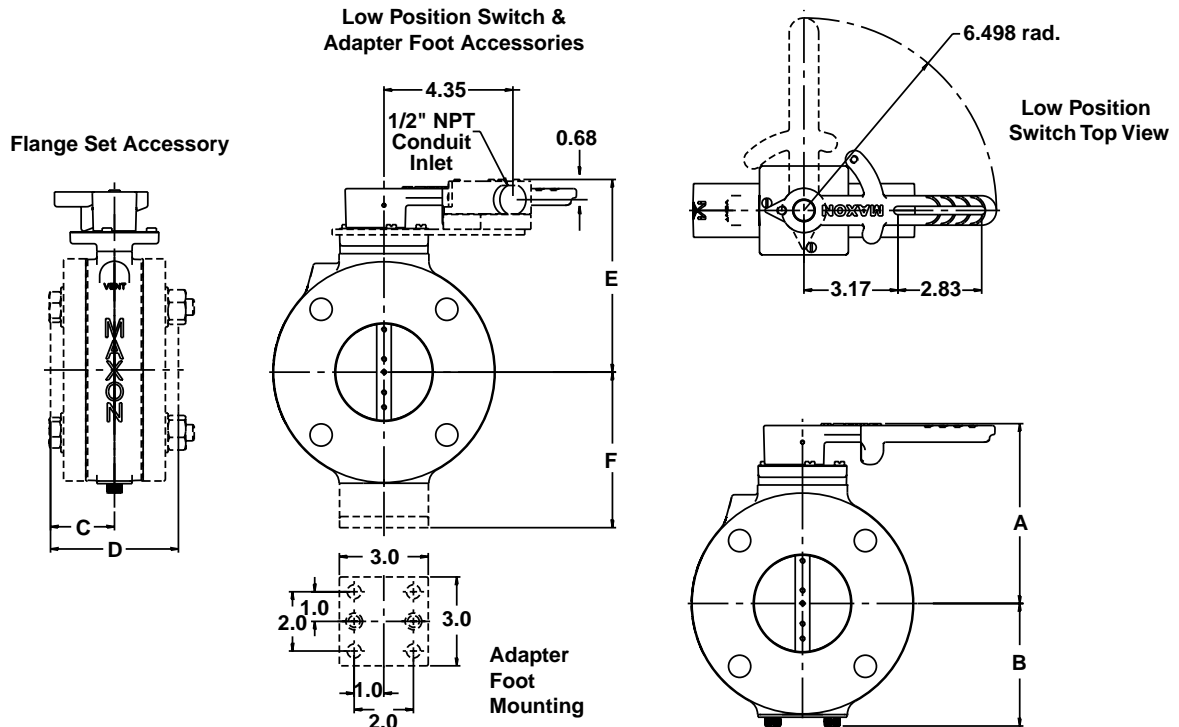

Cast Iron Bodies

Size	A	B	C	D	E	F
1"	5.08	2.91	1.41	2.82	5.50	4.00
1.25"	5.51	3.16	1.53	3.06	6.00	4.25
1.5"	5.51	3.16	1.60	3.20	6.00	4.25
2"	5.51	3.41	1.91	3.81	6.00	4.50
2.5"	6.08	4.14	2.09	4.18	6.50	5.25
3"	6.08	4.14	2.16	4.32	6.50	5.25
4"	6.63	5.28	2.41	4.81	7.13	6.38

Carbon Steel Bodies

Size	A	B	Thrd. C	Welded C	Thrd. D	Welded D	E	F
1"	5.08	2.91	1.41	1.41	2.82	2.82	5.50	4.00
1.25"	5.51	3.16	1.53	1.53	3.06	3.06	6.00	4.25
1.5"	5.51	3.16	1.60	1.60	3.20	3.20	6.00	4.25
2"	5.51	3.41	1.91	1.91	3.81	3.81	6.00	4.50
2.5"	6.08	4.14	2.09	2.09	4.18	4.18	6.50	5.25
3"	6.08	4.14	2.16	2.16	4.32	4.32	6.50	5.25
4"	6.63	5.28	2.41	2.41	4.81	4.81	7.13	6.38

Brass Bodies

Size	A	B	Thrd. C	Solder C	Thrd. D	Solder D	E	F
1"	5.08	2.91	1.41	1.78	2.82	3.81	5.50	4.00
1.25"	5.51	3.16	1.53	1.84	3.06	3.81	6.00	4.25
1.5"	5.51	3.16	1.60	1.92	3.20	3.97	6.00	4.25
2"	5.51	3.41	1.91	2.51	3.81	5.13	6.00	4.50
2.5"	6.08	4.14	2.06	2.79	4.11	5.48	6.50	5.25
3"	6.08	4.14	2.16	2.85	4.32	5.70	6.50	5.25

Valve Weight - Manual Valves (in lbs.)

Valve Size	Body Material		
	Cast Iron	Carbon Steel	Brass
1"	8.1	8.5	9.3
1.25"	9.6	10.2	11.2
1.5"	9.4	10.0	10.9
2"	13.2	14.1	15.6
2.5"	20.2	21.7	24.1
3"	19.0	20.4	22.7
4"	27.6	29.8	---

Note: All weights are approximate and do not include accessories

Pipe threads on this page conform to NPT (ANSI Standard B2.1)

Dimensions *(in inches)* Series "A" SYNCHRO Control Valves

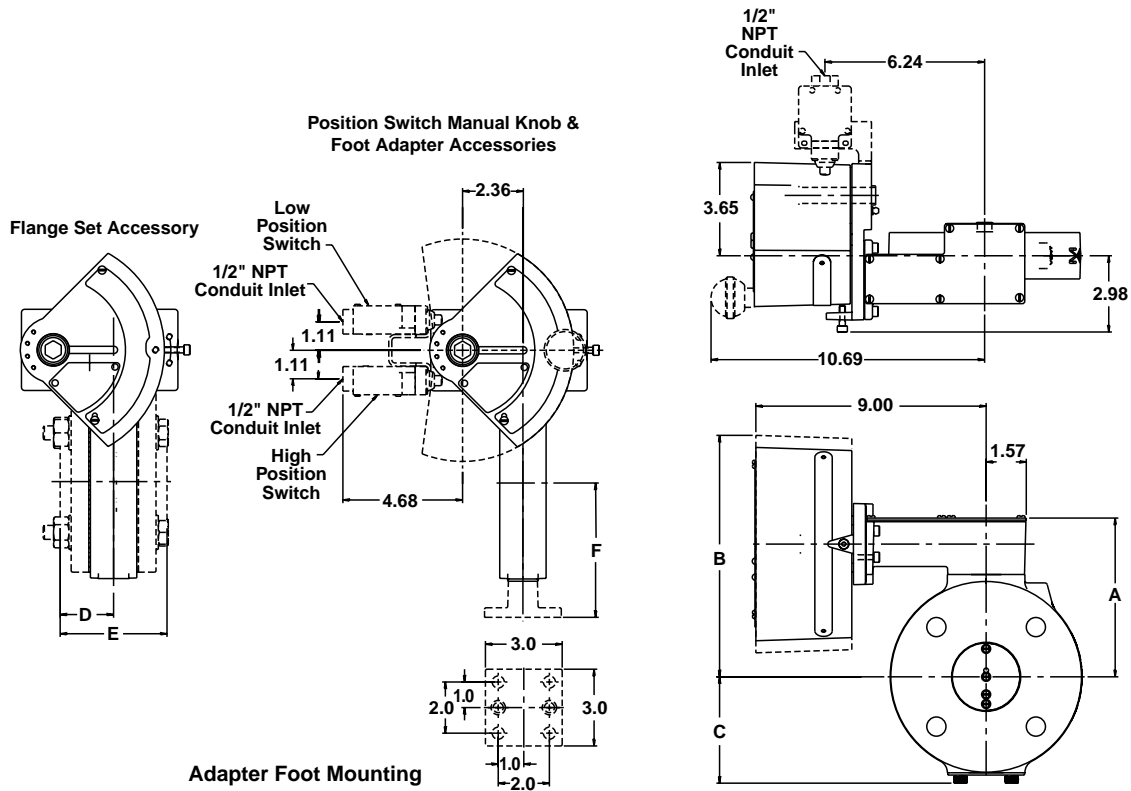

Cast Iron Bodies

Size	A	B	C	D	E	F
1"	5.06	8.44	2.91	1.41	2.82	4.00
1.25"	5.56	8.94	3.16	1.53	3.06	4.25
1.5"	5.56	8.94	3.16	1.60	3.20	4.25
2"	5.56	8.94	3.41	1.91	3.81	4.50
2.5"	6.06	9.44	4.14	2.09	4.18	5.25
3"	6.06	9.44	4.14	2.16	4.32	5.25
4"	6.69	10.06	5.28	2.41	4.81	6.38

Carbon Steel Bodies

Size	A	B	C	Thrd. D	Welded D	Thrd. E	Welded E	F
1"	5.06	8.44	2.91	1.41	1.41	2.82	2.82	4.00
1.25"	5.56	8.94	3.16	1.53	1.53	3.06	3.06	4.25
1.5"	5.56	8.94	3.16	1.60	1.60	3.20	3.20	4.25
2"	5.56	8.94	3.41	1.91	1.91	3.81	3.81	4.50
2.5"	6.06	9.44	4.14	2.09	2.09	4.18	4.18	5.25
3"	6.06	9.44	4.14	2.16	2.16	4.32	4.32	5.25
4"	6.69	10.06	5.28	2.41	2.41	4.81	4.81	6.38

Brass Bodies

Size	A	B	C	Thrd. D	Solder D	Thrd. E	Solder E	F
1"	5.06	8.44	2.91	1.41	1.78	2.82	3.81	4.00
1.25"	5.56	8.94	3.16	1.53	1.84	3.06	3.81	4.25
1.5"	5.56	8.94	3.16	1.60	1.92	3.20	3.97	4.25
2"	5.56	8.94	3.41	1.91	2.51	3.81	5.13	4.50
2.5"	6.06	9.44	4.14	2.06	2.79	4.11	5.48	5.25
3"	6.06	9.44	4.14	2.16	2.85	4.32	5.70	5.25

Valve Weight - SYNCHRO Valves *(in lbs.)*

Valve Size	Body Material		
	Cast Iron	Carbon Steel	Brass
1"	17.6	18.0	18.8
1.25"	19.1	19.7	20.7
1.5"	18.9	19.5	20.4
2"	22.7	23.6	25.1
2.5"	29.7	31.2	33.6
3"	28.5	29.9	32.2
4"	37.1	39.3	---

Note: All weights are approximate and do not include accessories

Pipe threads on this page conform to NPT (ANSI Standard B2.1)

Dimensions *(in inches)*

MICRO-RATIO® Valve Arrangements (right hand arrangement shown)

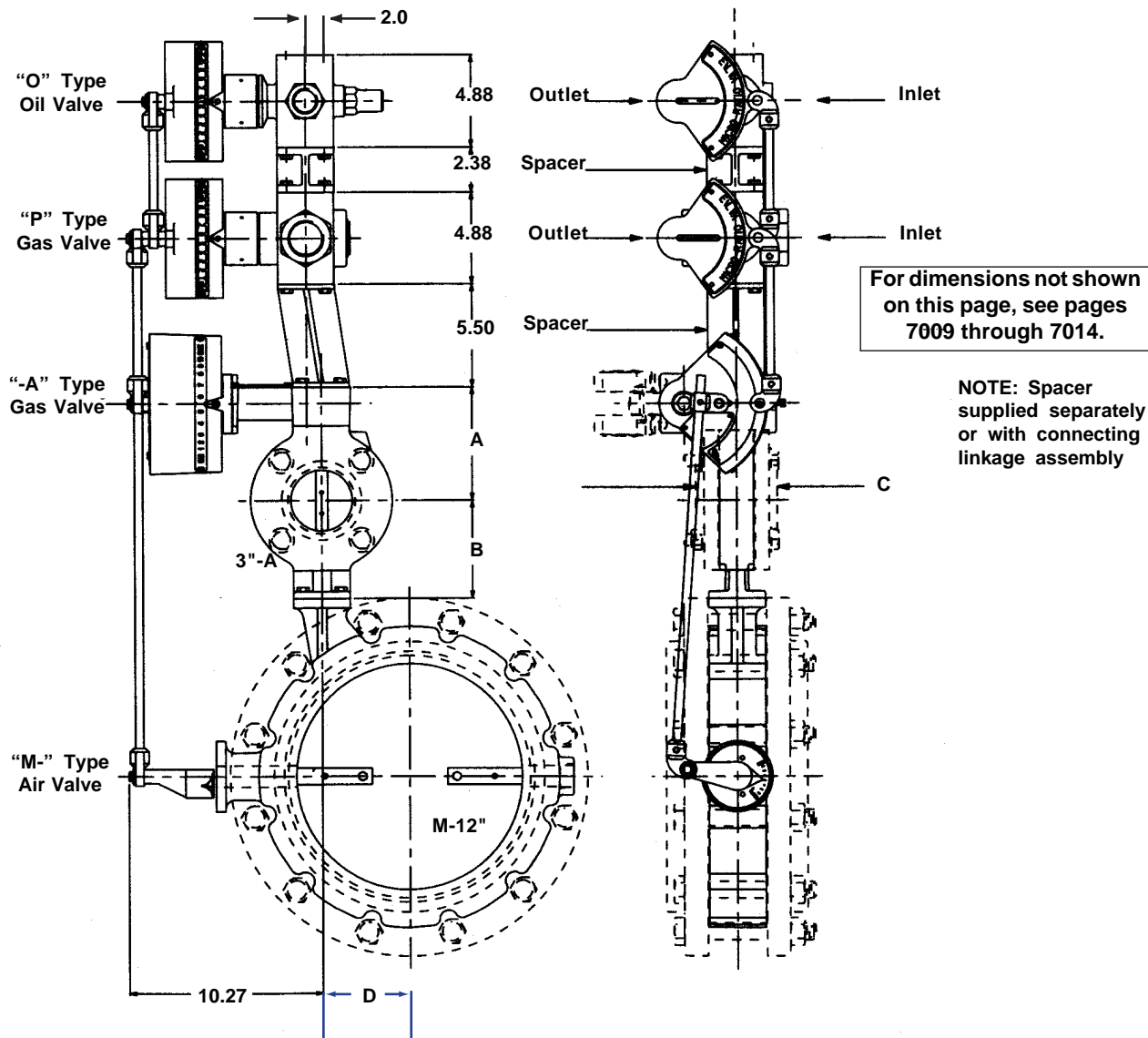

SYNCHRO Gas Valves - Butterfly Type

Size	A	B	C	C Brass
1"	5.06	4.00	2.82	2.82
1.25"	5.56	4.25	3.06	3.06
1.5"	5.56	4.25	3.20	3.20
2"	5.56	4.50	3.81	3.81
2.5"	6.06	5.25	4.18	4.11
3"	6.06	5.25	4.32	4.32
4"	6.69	6.38	4.81	---

"M-" Air Valves - Dimension D

Size	D
M- 1-1/2" thru M-6"	---
M-8"	1.12
M-10"	3.62
M-12"	4.62
M-14"	5.75
M-16"	6.62
M-18"	7.62

Note: Dimension "D" is dependent upon the size of air valve selected.

Pipe threads on this page conform to NPT (ANSI Standard B2.1)

Accessories

Position switches

for electrical indication of valve position

Standard Low Fire Start (LFS) switch opens the circuit when valve leaves minimum position. **Hi/Lo fire position switch set** includes (2) SPDT switches. One switch may be field-set to activate at high position, while the other is set to activate at low position.

SYNCHRO Valves

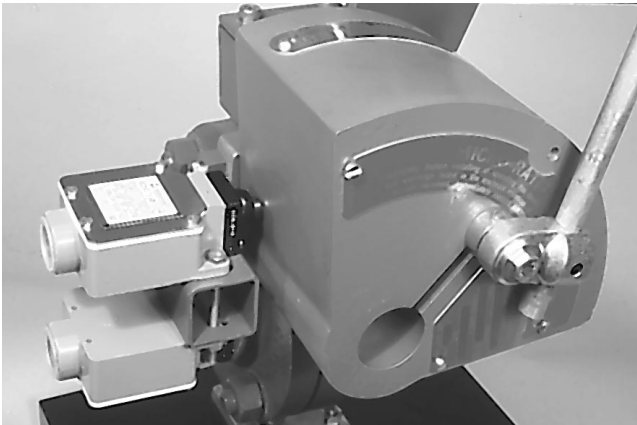

Manual Handle Valves



Connecting Base and Linkage Assemblies

Maxon has designed a broad range of Connecting Base and Linkage assemblies (CB & L) to properly position and align the popular operators for control of Maxon flow control valves.

Proper position and alignment are essential for smooth and trouble-free operation of flow control valves.

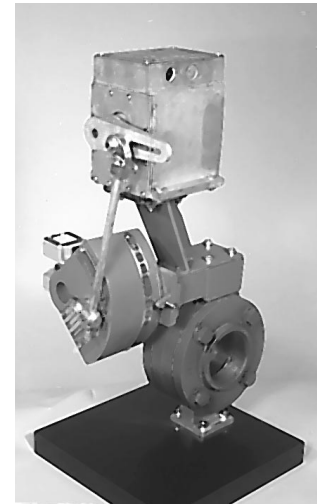

Other Accessories

Poppet to A- SYNCHRO Spacer Kit



Universal Adapter Bracket Kit



Component Identification Series "A" Manual Control Valves

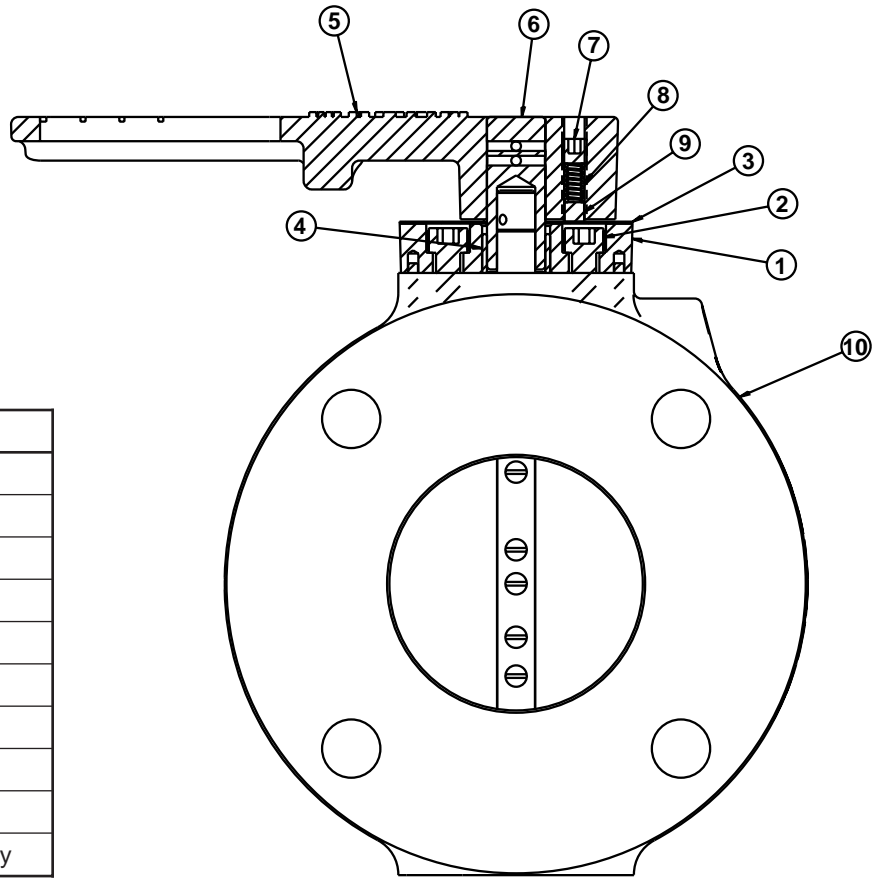

Legend

Item	Description
1	Manual Valve Adapter
2	Cap Screws
3	Indicator Plate
4	Manual Shaft Bushing
5	Manual Handle
6	Manual Sleeve
7	Set Screw
8	Brake Spring
9	Brake
10	Valve Body Sub-Assembly

Component Identification

Series "A" SYNCHRO Flow Control Valves

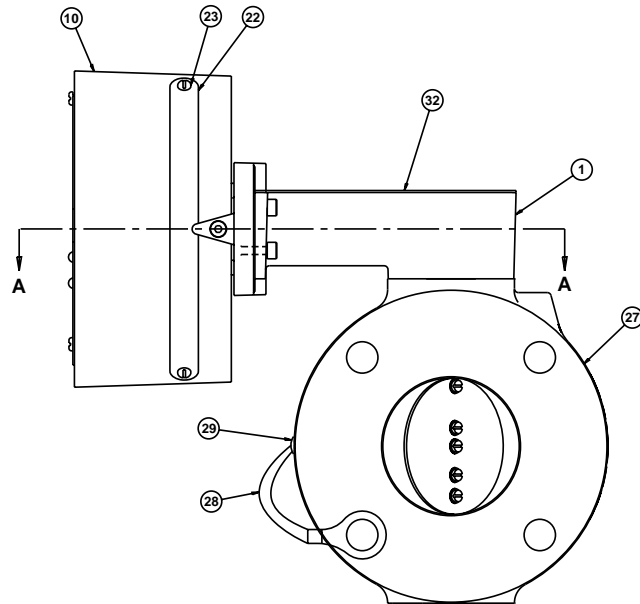
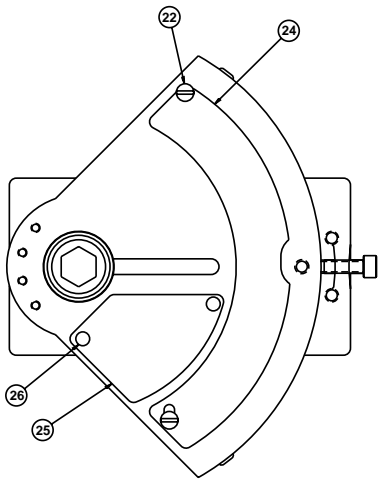

Legend

Item	Description
1	Housing
2	Operating Rack
3	Operating Rack Bearings
4	Compression Spring
5	Spring Retainer
6	Base
7	Locking Screw
8	Base Bolts
9	Lube Fitting
10	Screw Carrier
11	Cam Screws
12	Retainer Screws
13	Cam Strips
14	Yoke
15	Dust Cover
16	Screw Carrier Bolt
17	Washer
18	Bearing
19	Washer
20	Bearing
21	Set Screw
22	Indicator Strip
23	Plate Screw
24	Cam Screw Cover Plate
25	Identification Plate
26	Drive Screw
27	Valve Body Sub-Assembly
28	Ground Straps (Brass Only)
29	Drive Screw (Brass Only)
30	Spur Gear
31	Cap Screws
32	Cover Plate

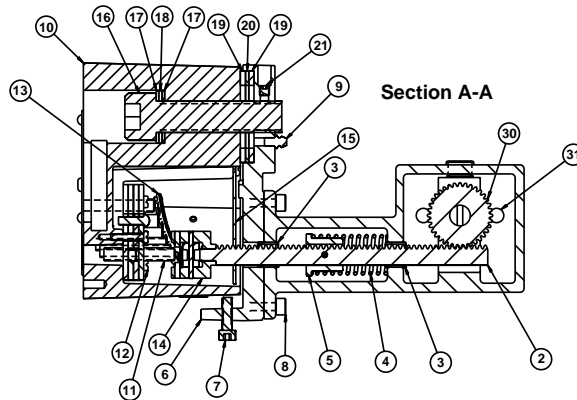

Suggested Maintenance/Inspection Procedures Series "A" SYNCHRO Flow Control Valves

Valve Lubrication Suggestions

Some lubrication of moving parts may be required. All moving parts, O-rings and cam strips are lubricated at time of manufacturing. A periodic inspection should be performed to insure all parts continue to move freely and function properly. A periodic re-application of lubricant will extend the service life of your Maxon MICRO-RATIO® Valve.

The following lubricants are suggested:

<u>Manufacturer</u>	<u>Lubricant</u>
Keystone Div., Philadelphia, PA	#84-EP-2, NLGL #2 Lithium base grease
Standard Oil Co. (of Indiana)	Stanolith grease #42
Shell Oil Co.	Alvania grease #1
Stewart Warner Corp.	Alemite lubricant #32



Representado Por:
INSURCOL LTDA
Calle 41 No 21-32
Tel: (097) 6700100
Fax: (097) 6422870
Email: info@insurcol.com