



## Mechanical Level Switches

Form 912

**SOR mechanical level switches** are rugged, industrial products specifically designed for versatility of application. This catalog contains application and ordering data for float and displacer-operated level switches. Switches are available with flanged or sealed chambers or as insertion models.

Options available for each type of switch include: switch type and number, housing type, chamber material, process connections, accessories, and more. Units may be customized to suit customers' needs.

Inside this catalog you will find solutions to your level sensing puzzles. SOR mechanical level switches have many configurations available. If you don't see what you need, we will engineer a solution for your application.



Design and specifications are subject to change without notice.

### Features and Benefits

- *Five-year warranty*
- *ASME Section IX qualified welding system*
- *Designed to ANSI/ASME B31.1 and B31.3 guidelines*
- *Hermetically sealed switching mechanisms available*
- *Stainless steel switching mechanisms*
- *High temperature capability*
- *Wide variety of explosion proof housings*
- *Versatile switching mechanisms which retro-fit into other manufacturers' units*
- *Worldwide listings and certifications*
- *Quick worldwide delivery*
- *Only ASTM grade materials with certified mill test reports used*

# Mechanical Level Switches

## High Quality Chambers

SOR uses high quality design, ASTM materials and ANSI/ASME construction to provide a significantly better standard product. With SOR products, a customer never needs to worry if they are getting a good design - all standard products meet the following criteria as a minimum.

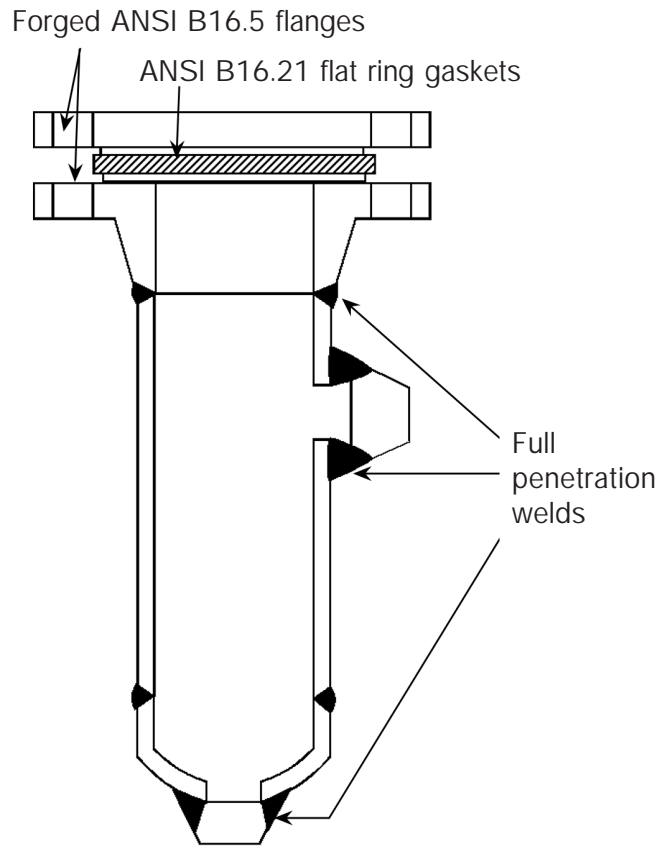

*SOR Standard Product*

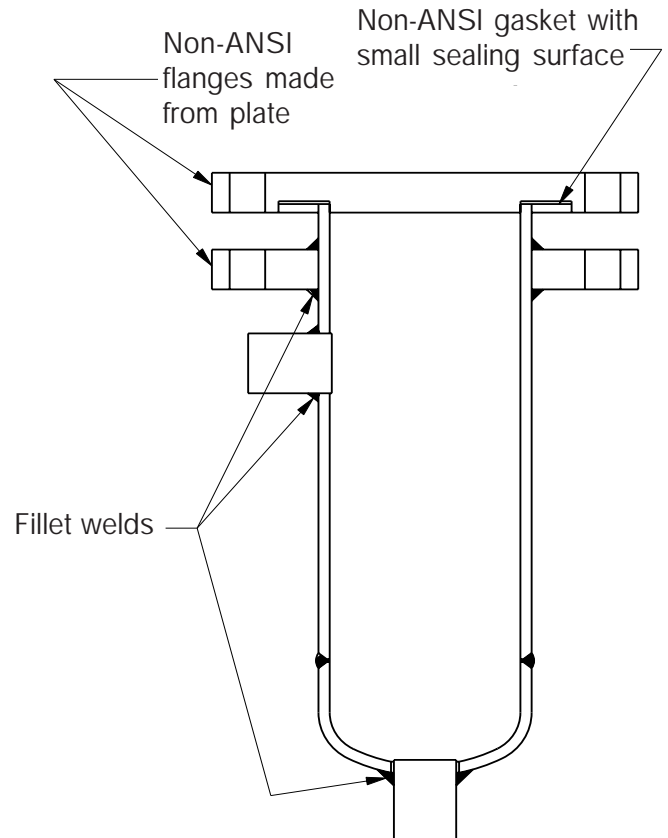

*Other Manufacturer's Standard*

# Mechanical Level Switches

## Principles

### Float Operated Level Switches Model Series 100, 200 and 300

The float rides on the process liquid surface, precisely tracking liquid surface motion.

Rising liquid level lifts the float, sliding the attraction sleeve up inside the enclosing tube and into the magnetic field to actuate the electrical or pneumatic switch (signaling liquid presence).

Subsequently, falling liquid level lowers the float, drawing the attraction sleeve out of the magnetic field to deactivate the electrical or pneumatic switch (signaling liquid absence). Float-type level switches are generally able to handle high temperature applications, and sometimes prove useful for close interface detection.

Floats can operate up to three switching elements. Independent switching levels can be obtained with tandem floats. Consult the factory for special float switching arrangements.

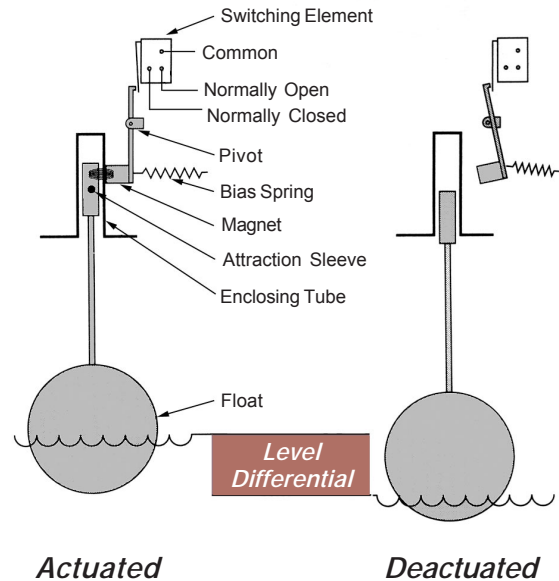

### Float Operated Level Switches Model Series 108/208 and 400

The float rides on the process liquid surface, precisely tracking liquid surface motion.

Rising liquid level lifts the float via a pivot mechanism, sliding the attraction sleeve down inside the enclosing tube and out of the magnetic field to deactivate the electrical or pneumatic switch (signaling liquid presence).

Subsequently, falling liquid level lowers the float, drawing the attraction sleeve into the magnetic field to actuate the electrical or pneumatic switch (signaling liquid absence). Float-type level switches are generally able to handle high temperature applications.

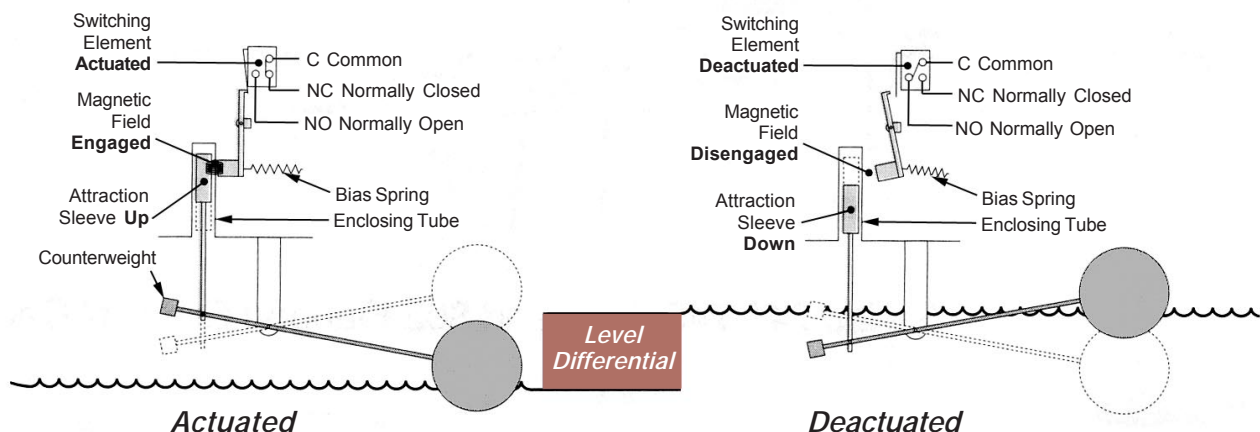

### Displacer Operated Level Switches Model Series 700, 730, 740, 750 and 800

Displacer controls offer alternate features to the float operated control. The sensor is a weight (displacer), heavier than the liquid, which is suspended by a spring. When liquid contacts the displacer, a buoyancy force is produced, which causes the effective weight of the displacer to change. This causes the spring to retract slightly to a new equilibrium position. When the spring retracts, the attraction sleeve also moves upward into the field of the external magnet, thus overcoming the force of the bias spring and actuating the switching element.

This principle provides for narrow or wide switching differential, and allows switching point alteration by moving the displacer(s) up or down the suspension cables.

Displacers can be arranged in combinations of narrow and wide differential to operate up to three switching stages. Displacer controls operate under higher pressure conditions than float operated switches.

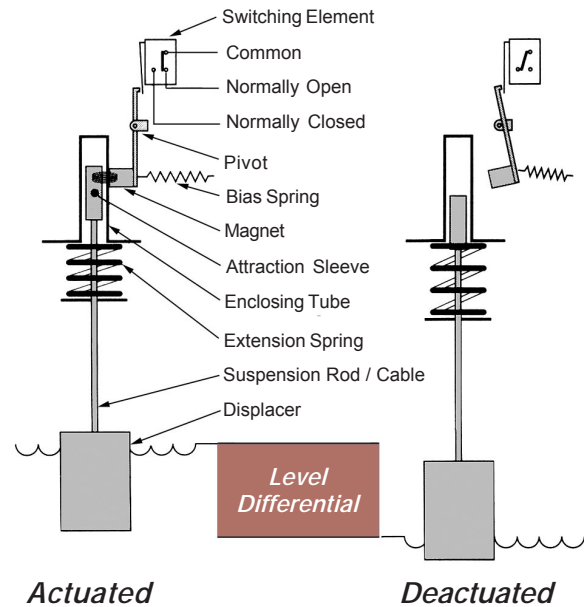

### **General**

- Rugged carbon steel or stainless steel construction
- Five year manufacturer's warranty
- Quick, worldwide delivery
- All ASTM materials (see page 57)
- Quality management system is registered to ISO-9001

### **Standard Chamber Materials**

- All SOR level switch chambers are constructed using ASTM grade materials with full material certification. Mill Test Reports are kept on file for all raw materials. Copies are available upon request at the time of order placement.

#### **Carbon Steel Construction**

Chamber Center Section	A106 Grade B
Flanges/Weld Fittings	A105
Weld Cap	A234-WPB
Studs/Nuts	A193-B7/A194-2H

#### **Stainless Steel Construction**

Chamber Center Section	A312-TP316/316L
Flanges/Weld Fittings	A182-316/316L
Weld Cap	A403-316/316L
Studs/Nuts	A193-B7/A194-2H

### **Gaskets**

- All standard models are provided with a Nitrile binder composite gasket that is selected for its resistance to hydrocarbons and steam.
- For high temperature, high pressure or NACE constructed units, a spiral wound gasket is used with 316SS wound around Grafoil.
- Extreme high pressure model 802 uses a soft iron ring joint gasket on the chamber head flange.

### **Internal Trim**

- All sensing elements (floats and displacers) are constructed of either 316/316LSS or porcelain as a minimum.
- Attraction sleeves are available in 400SS as a standard, with 316/316LSS or other exotic metals as an option.
- All other wetted internal parts are 316SS or better. Displacer springs are made of Inconel 600.

#### **Switching Mechanisms**

SOR switching mechanisms are designed for use in punishing industrial conditions.

- All stainless steel construction - no aluminum or brass.
- Temperature ratings available from -65°F (-54°C) to 1000°F (538°C) on dry, non-condensing services.
- Condensing service (steam) temperature ratings available up to 650°F (343°C), and up to 1000°F (538°C) with protection (see page 51).
- Available switching mechanisms are hermetically sealed, standard open contacts, pneumatic, or mercury contacts.
- Agency listings are available on most switch mechanisms: UL, CSA, ATEX or SAA (Australia).

#### **Switch Housings**

All SOR switch housings are made from rugged castings. Materials are copper-free aluminum or cast iron. A wide range of explosion proof ratings and agency listings are available.

#### **Quality Assurance**

SOR maintains a high level of quality throughout our corporation. Many quality assurance features are built into our products.

- ISO 9001 certified engineering design and production system (certified since 1993).
- Level welded chambers designed to the guidelines of ASME B31.1 and B31.3 (inspection certificate available – see page 55).
- All welders and weld procedures are qualified and maintained to ASME Section IX.
- All ASTM grade materials used - Certified Mill Test Reports required on all raw materials.

#### **Product Support**

SOR has a full-time applications engineering staff dedicated to solving your mechanical level switch problems.

- Engineers and technicians are knowledgeable about sales and production techniques, and are dedicated to providing the best solution to our customers at the best price.